

PRU-ICSS EtherCAT Slave Firmware Data Sheet

FEATURES

- All EtherCAT Commands (NOP, APRD, APWR, APRW, FPRD, FPWR, FPRW, BRD, BWR, BRW, LRD, LWR, LRW, ARMW and FRMW)
- 8 FMMU support
- 8 SM support
- 8KB(AM335, AMIC110) /28KB (AM437, AM57) /60KB (K2G) of Process Data RAM
- Distributed clocks (DC)
 - 64-bit DC
 - SYNC0 out generation single shot and cyclic mode support
 - SYNC1 out generation - SYNC1 cycle time multiple of SYNC0 cycle time
 - Latch0 and Latch1 inputs
 - System Time PDI control
- DL Loop Control
 - Using MII_RX_LINK (fast - depending on PHY link loss detection latency) – mandatory for cable redundancy support
 - Using PRU-ICSS MDIO state machine – not recommended for cable redundancy support
- Interrupts – AL and ECAT events
 - SYNC0, SYNC1 and PDI interrupt events on external SOC pins
- Watchdog – PDI and SM
- Error Counters
 - RX Invalid Frame Counter Port 0/1
 - RX ERR Counter Port 0/1
 - Forwarded Error Counter Port 0/1
 - ECAT Processing Unit Error Counter
- LED – Run, Error and Port0/1 activity based on firmware feedback
 - Controlled via GPIO from Host CPU based on firmware feedback or by PHY directly
- EEPROM Emulation for ESI EPPROM support
 - External flash for non-volatile storage support
- Management Interface for PHY over EtherCAT
- PHY address configuration and host side PRU-ICSS MDIO API for PHY programming
- Cable Redundancy support



Please be aware that an important notice concerning availability, standard warranty, and use in critical applications of Texas Instruments semiconductor products and disclaimers thereto appears at the end of this data sheet.

Description

PRU-ICSS EtherCAT Software from TI can be used by customers to add EtherCAT function on top of Processor SDK to Sitara processors .PRU-ICSS EtherCAT firmware implements EtherCAT slave controller layer2 functionality with two MII ports (one IN and one OUT port per PRU-ICSS) in accordance with ETG1000 specification [5].This provides EtherCAT slave ASIC like functionality integrated into Sitara Processors with PRU-ICSS IP.

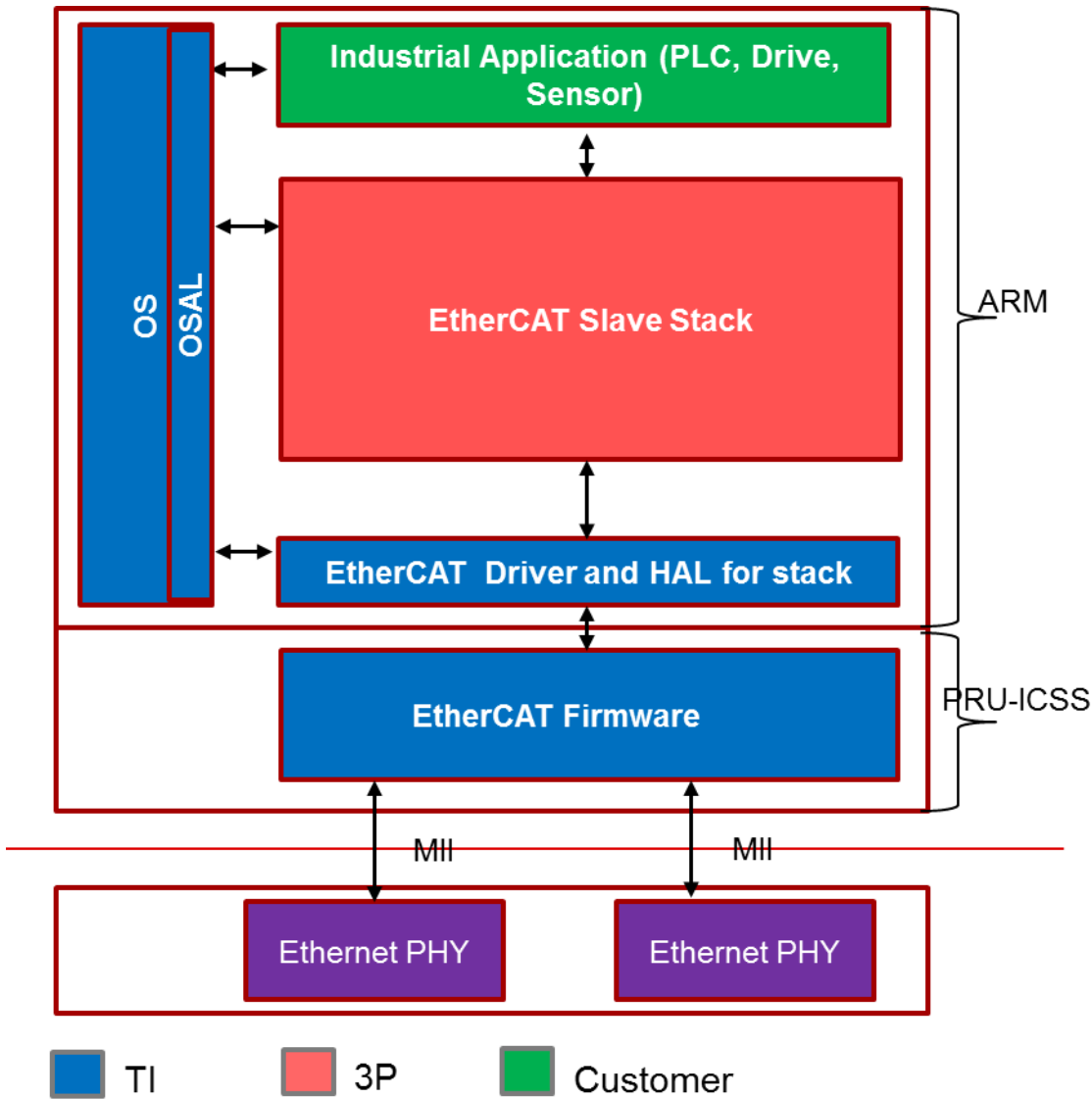

I

EtherCAT firmware for PRU-ICSS is a black box product maintained by TI. EtherCAT driver allows loading and run EtherCAT firmware and interface with ESC firmware. This also includes PDI/Hardware abstraction layer (HAL) for popular EtherCAT stacks. EtherCAT driver is provided in full source so that customers can adapt this implementation to own hardware and Operating Systems.

EtherCAT Slave Stack typically consists of PDI/HAL, EtherCAT stack and user application which can be

customized, the behavior of the generic EtherCAT stack is described in ETG.1000 Specification [6]. Key components are EtherCAT state machine, real time Process Data Interface and Mailbox interface which provides non-real time interfaces like (AoE, CoE, EoE, FoE and SoE)

Performance Summary

A 300 MHz CPU speed is sufficient to support a simple IO or sensor application. More complex applications can use higher speed grades of up to 1.5 GHz depending on SoC. The PRU core speed remains 200 MHz for all speed grades. AM572x IDK running default EtherCAT application (5 bytes output and 7 bytes input) on Cortex-A15 at nominal OPP (1GHz) can communicate with PLC at cycle time as low as 31.25 us with Distributed Clocks (SYNC0) enabled

Memory Summary

This section describes memory usage of the EtherCAT PRU-ICSS firmware and EtherCAT driver for Cortex-A driver

Table 1 EtherCAT PRU-ICSS Firmware Memory Statistics

Memory	AM335x/AMIC110	AM437x/AM57xx	K2G	Remarks
PRU-ICSS Shared RAM	12 KB	32 KB	64 KB	4KB Register memory and 8KB/28KB/60KB Process Data memory

Table 2 EtherCAT Driver Memory Statistics

Section	Memory
.text (executable code)	8.20 KB
.rodata (constant data)	2KB
.data (initialized non-constant data –writable static)	.36 KB
.bss (uninitialized data)	2.08 KB

NOTE: EtherCAT driver object files (tiescbp.o, tieschw.o and tiesc_fw_cir_buff.o) are used for this analysis with gcc-arm-none-eabi-4_9-2015q3 toolchain options : -mcpu=cortex-a15 -mtune=cortex-a15 -marm -mfloat-abi=hard -mfpu=neon -O2

Hardware Requirements

- Sitara Processor with PRU-ICSS IP and EtherCAT support
- ESC implementation uses following interrupts mapped to Host Interrupt Controller say GIC

Stack/application interrupts		
ESC firmware interrupt	Host Interrupt	Remarks
DC SYNC0 OUT	PRU_ICSS_EVTOUT1	Used in DC mode for syncing the application
DC SYNC1 OUT	PRU_ICSS_EVTOUT2	Used in DC mode for syncing the application
PDI Interrupt	PRU_ICSS_EVTOUT3	AL event/PDI interrupt to host stack
ESC command ACK	PRU_ICSS_EVTOUT4	ESC firmware command completion ACK to Host

- ESC implementation makes use of one instance of HW spinlock (SPINLOCK_LOCK_REG0)
 - For K2G spinlock is implemented using HW Semaphore block (SEM_0 instance)

- HW signals required to implement EtherCAT slave functionality is shown below, this info needs to be used in conjunction with <http://www.ti.com/tool/PINMUXTOOL>

NOTE: w.r.t prX, X is 1 or 2 (respectively PRU-ICSS1 or PRU-ICSS2 – refer to SOC TRM for availability)

Table 3 PRU-ICSS signals required for EtherCAT functionality

Signal name		Description
PRU-ICSS MDIO		
prX_mdio_mdclk	Mandatory	MDIO clock
prX_mdio_data	Mandatory	MDIO data
PRU-ICSS MII PORT0 (IN PORT) and PRU-ICSS MII PORT1 (OUT PORT)		
prX_mii_mt0_clk	Mandatory	MII0 and MII1 transmit clock
prX_mii_mt1_clk		
prX_mii0_txd3	Mandatory	MII0 and MII1 transmit data3
prX_mii1_txd3		
prX_mii0_txd2	Mandatory	MII0 and MII1 transmit data2
prX_mii1_txd2		
prX_mii0_txd1	Mandatory	MII0 and MII1 transmit data1
prX_mii1_txd1		
prX_mii0_txd0	Mandatory	MII0 and MII1 transmit data0
prX_mii1_txd0		
prX_mii0_rxd3	Mandatory	MII0 and MII1 receive data3
prX_mii1_rxd3		
prX_mii0_rxd2	Mandatory	MII0 and MII1 receive data2
prX_mii1_rxd2		
prX_mii0_rxd1	Mandatory	MII0 and MII1 receive data1
prX_mii1_rxd1		
prX_mii0_rxd0	Mandatory	MII0 and MII1 receive data0
prX_mii1_rxd0		
prX_mii0_txen	Mandatory	MII0 and MII1 TX enable
prX_mii1_txen		
prX_mii_mr0_clk	Mandatory	MII0 and MII1 receive clock
prX_mii_mr1_clk		
prX_mii0_rxdv	Mandatory	MII0 and MII1 RX data valid
prX_mii1_rxdv		
prX_mii0_rxer	Mandatory	MII0 and MII1 RXERR
prX_mii1_rxer		
prX_mii0_rxlink	Recommended	Enhanced link detection**/Redundancy support - connect LED_LINK/LED_SPEED from PHY here
prX_mii1_rxlink		
PRU-ICSS Distributed Clocks (Network clock synchronization)		
prX_edc_sync0_out	Recommended (for DC capable slaves)	SYNC0 out - Time synchronized OUT0
prX_edc_sync1_out	Optional	SYNC1 out - Time synchronized OUT1 (depends on SYNC0)
prX_edc_latch0_in	Optional	LATCH0 in (Time stamp latch input0)

prX_edc_latch1_in	Optional	LATCH1 in (Time stamp latch input1)
PRU-ICSS PDI Interrupt		
prX_edio_data_out0	Optional	PDI ISR output to external SOC pin (via one of the 8 PRU-ICSS digio outputs. PDI ISR pin can be selected via vendor specific register at offset 0xE0A.
prX_edio_data_out1		
prX_edio_data_out2		
prX_edio_data_out3		
prX_edio_data_out4		
prX_edio_data_out5		
prX_edio_data_out6		
prX_edio_data_out7		
ESC LED control*		
Any available GPIOs can be used for this purpose. Requires 4 LED_RUN (Green), LED_ERR(Red), LED_LINK/ACT0, LED_LINK/ACT0	Mandatory	RUN and ERR LED are controlled by stack. LED_LINK/ACT0/1 may be controlled by stack or directly by Ethernet PHY. If controlled by stack using GPIO, ESC firmware provides activity feedback via 0xE00 (Port0) and 0xE04 (Port1) registers

*: Refer to ETG.1300 – Indicator and Labeling specification [7] and ETG.9001 – Marking Rules [8] to make sure that product conformance requirement are met

Software

EtherCAT slave firmware, driver, examples and associated documentation for Sitara Processors is available from <http://www.ti.com/tool/PRU-ICSS-ETHERCAT-SLAVE>. EtherCAT software runs on top of TI Processor SDK

More details can be found here

http://processors.wiki.ti.com/index.php/Industrial_Protocol_Package_Software_Developer_Guide

http://processors.wiki.ti.com/index.php/Processor_SDK_RTOS_Software_Developer_Guide

http://processors.wiki.ti.com/index.php/Processor_SDK_Linux_Software_Developer's_Guide

Certification Information

Certification was done on [AM335x ICEv1](#) board using EtherCAT firmware build (1.2.42) and Beckhoff SSC 5.0.1 EtherCAT slave stack during Feb 2013

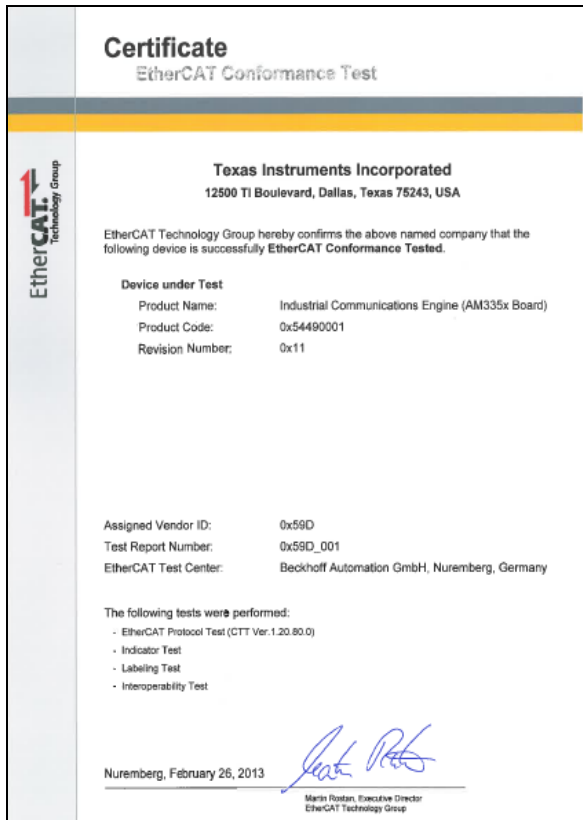

References

1. EtherCAT on Sitara Processors - spry187e
2. Industrial Communications Solution Guide - slyy050b
3. [EtherCAT Communications Development Platform](#)
4. [Single Chip Drive for Industrial Communications and Motor Control](#)
5. ETG.1000 part 4 Data link Layer protocol specification
6. ETG.1000 part 6 Application link Layer protocol specification
7. ETG.1300 Indicator and Labelling specification
8. ETG.9001 Marking Rules
9. [EtherCAT ESC datasheet Section 1 - Technology](#)
10. [EtherCAT ESC datasheet Section 2 - Register Description](#)
11. http://processors.wiki.ti.com/index.php/PRU_ICSS_EtherCAT_firmware_API_guide#PRU-ICSS_EtherCAT_Register_List
12. [Beckhoff SSC documentation](#) available as part of ET9300 EtherCAT Slave Stack Code (http://www.ethercat.org/memberarea/stack_code.aspx)
13. [EtherCAT Slave Implementation Guide from ETG](#)
14. ESD EtherCAT Slave Stack : <https://esd.eu/en/products/ethercat-slave>
15. icECAT Linux SDK from ibv : <http://www.ibv->

Acronyms

Acronym	Description
PRUSS	Programmable RealTime Unit Sub System
PRU-ICSS	Programmable RealTime Unit - Industrial Communication Sub System - PRUSS with industrial communication support
ESC	EtherCAT Slave Controller
ECAT	EtherCAT
PDI	Process Data Interface (Host interface to ESC)
FMMU	Fieldbus Memory Management Unit
SM	Sync Manager
SSC	Slave Stack Code (from Beckhoff)
DL	Datalink Layer
ESI	EtherCAT Slave Information
ISR	Interrupt Service Routine
AL	Application Layer
LED	Light Emitting Diode
HAL	Hardware Abstraction Layer
AoE	ADS over EtherCAT
CoE	CANopen application profile over EtherCAT
EtE	Ethernet over EtherCAT
FoE	File Transfer over EtherCAT
SoE	Servo drive profile over EtherCAT
PDO	Process Data Object
PLC	Programmable Logic Controller
HAL	Hardware Abstraction Layer
MDIO	Management Data Input Output
MII	Media Independent Interface
ASIC	Application Specific Integrated Circuit
OS	Operating Systems
SoC	System On Chip
IDK	Industrial Development Kit (EVM)

IMPORTANT NOTICE

Texas Instruments Incorporated and its subsidiaries (TI) reserve the right to make corrections, enhancements, improvements and other changes to its semiconductor products and services per JESD46, latest issue, and to discontinue any product or service per JESD48, latest issue. Buyers should obtain the latest relevant information before placing orders and should verify that such information is current and complete. All semiconductor products (also referred to herein as “components”) are sold subject to TI’s terms and conditions of sale supplied at the time of order acknowledgment.

TI warrants performance of its components to the specifications applicable at the time of sale, in accordance with the warranty in TI’s terms and conditions of sale of semiconductor products. Testing and other quality control techniques are used to the extent TI deems necessary to support this warranty. Except where mandated by applicable law, testing of all parameters of each component is not necessarily performed.

TI assumes no liability for applications assistance or the design of Buyers’ products. Buyers are responsible for their products and applications using TI components. To minimize the risks associated with Buyers’ products and applications, Buyers should provide adequate design and operating safeguards.

TI does not warrant or represent that any license, either express or implied, is granted under any patent right, copyright, mask work right, or other intellectual property right relating to any combination, machine, or process in which TI components or services are used. Information published by TI regarding third-party products or services does not constitute a license to use such products or services or a warranty or endorsement thereof. Use of such information may require a license from a third party under the patents or other intellectual property of the third party, or a license from TI under the patents or other intellectual property of TI.

Reproduction of significant portions of TI information in TI data books or data sheets is permissible only if reproduction is without alteration and is accompanied by all associated warranties, conditions, limitations, and notices. TI is not responsible or liable for such altered documentation. Information of third parties may be subject to additional restrictions.

Resale of TI components or services with statements different from or beyond the parameters stated by TI for that component or service voids all express and any implied warranties for the associated TI component or service and is an unfair and deceptive business practice. TI is not responsible or liable for any such statements.

Buyer acknowledges and agrees that it is solely responsible for compliance with all legal, regulatory and safety-related requirements concerning its products, and any use of TI components in its applications, notwithstanding any applications-related information or support that may be provided by TI. Buyer represents and agrees that it has all the necessary expertise to create and implement safeguards which anticipate dangerous consequences of failures, monitor failures and their consequences, lessen the likelihood of failures that might cause harm and take appropriate remedial actions. Buyer will fully indemnify TI and its representatives against any damages arising out of the use of any TI components in safety-critical applications.

In some cases, TI components may be promoted specifically to facilitate safety-related applications. With such components, TI’s goal is to help enable customers to design and create their own end-product solutions that meet applicable functional safety standards and requirements. Nonetheless, such components are subject to these terms.

No TI components are authorized for use in FDA Class III (or similar life-critical medical equipment) unless authorized officers of the parties have executed a special agreement specifically governing such use.

Only those TI components which TI has specifically designated as military grade or “enhanced plastic” are designed and intended for use in military/aerospace applications or environments. Buyer acknowledges and agrees that any military or aerospace use of TI components which have **not** been so designated is solely at the Buyer’s risk, and that Buyer is solely responsible for compliance with all legal and regulatory requirements in connection with such use.

TI has specifically designated certain components as meeting ISO/TS16949 requirements, mainly for automotive use. In any case of use of non-designated products, TI will not be responsible for any failure to meet ISO/TS16949.

Products

Audio	www.ti.com/audio
Amplifiers	amplifier.ti.com
Data Converters	dataconverter.ti.com
DLP® Products	www.dlp.com
DSP	dsp.ti.com
Clocks and Timers	www.ti.com/clocks
Interface	interface.ti.com
Logic	logic.ti.com
Power Mgmt	power.ti.com
Microcontrollers	microcontroller.ti.com
RFID	www.ti-rfid.com
OMAP Applications Processors	www.ti.com/omap
Wireless Connectivity	www.ti.com/wirelessconnectivity

Applications

Automotive and Transportation	www.ti.com/automotive
Communications and Telecom	www.ti.com/communications
Computers and Peripherals	www.ti.com/computers
Consumer Electronics	www.ti.com/consumer-apps
Energy and Lighting	www.ti.com/energy
Industrial	www.ti.com/industrial
Medical	www.ti.com/medical
Security	www.ti.com/security
Space, Avionics and Defense	www.ti.com/space-avionics-defense
Video and Imaging	www.ti.com/video
TI E2E Community	e2e.ti.com

Mailing Address: Texas Instruments, Post Office Box 655303, Dallas, Texas 75265
Copyright © 2017, Texas Instruments Incorporated